

# DIURNAL VARIATIONS IN PHYSICO-CHEMICAL CONDITIONS WITHIN INTERTIDAL ROCKPOOLS

By M. J. DANIEL

*Biological Sciences Division, Department of Science, Derby College of Art and Technology,  
Derby DE3 1GB*

and C. R. BOYDEN

*Applied Geochemistry Research Group, Imperial College, London SW7 2BP*

## INTRODUCTION

MUCH of what has been written about rockpools concerns the compilation of lists of organisms. Surprisingly few papers describe the ecology and interrelationships of rockpool species or the environment from a physico-chemical point of view.

The general description of the environment, found notably in Lewis (1964) and Newell (1970), is based principally on the work of Stephenson, Zoond and Eyre (1934), Pyefinch (1943) and also that of Klugh (1924) and Naylor and Slinn (1958). These investigations show conditions in shore pools to be far from stable; potentially important ecological factors such as dissolved oxygen, pH, temperature, and salinity exhibit wide diurnal and seasonal fluctuation.

This paper supplements existing information about diurnal changes within rock pools and emphasizes the variations at night, about which relatively little is known.

Notable recent studies have been made on rockpools in which tidal influences are very small namely the supra-littoral pools of the east coast of Scotland (Clark, 1968) and the pools of the Baltic where tidal range is negligible (Ganning, 1971). We describe intertidal pools for the most part in regular daily contact with the sea.

## MATERIALS AND METHODS

### 1. *Study Area details*

This investigation was conducted at St. Bride's Haven (O.S. map 138/151; ref. 800112), Pembrokeshire (Fig. 1), during a week of spring tides (maximum tidal range 7.2 m.) from 29 July to 5 August 1973. Almost unbroken sunshine by day, with light on-shore breezes, resulted in high air temperatures and intense levels of illumination. At night, cloud cover was sparse, the moon, in its first quarter, rose just before dawn, and again light breezes prevailed. Time of low water (B.S.T.) ranged from 13.00 (and 01.20) on the first day to 16.00 (and 04.20) on the last. The shore was therefore exposed for lengthy periods during both night and day.

St. Bride's Haven faces north-northwest. The pools studied are approximately 50-100 m west of the small sandy beach, on a rock platform which slopes gently for about 20 m below high water mark, dropping more steeply to the sea at low water. Landward the Old Red Sandstone rocks rise as a low cliff some 7 m high. The platform is corrugated with many low parallel ridges and is in places dissected by deep gulleys. Rockpools of all shapes and sizes abound in the mid-littoral region. Many plants and animals flourish on this shore which is moderately sheltered on the Ballantine exposure scale (Ballantine, 1961).

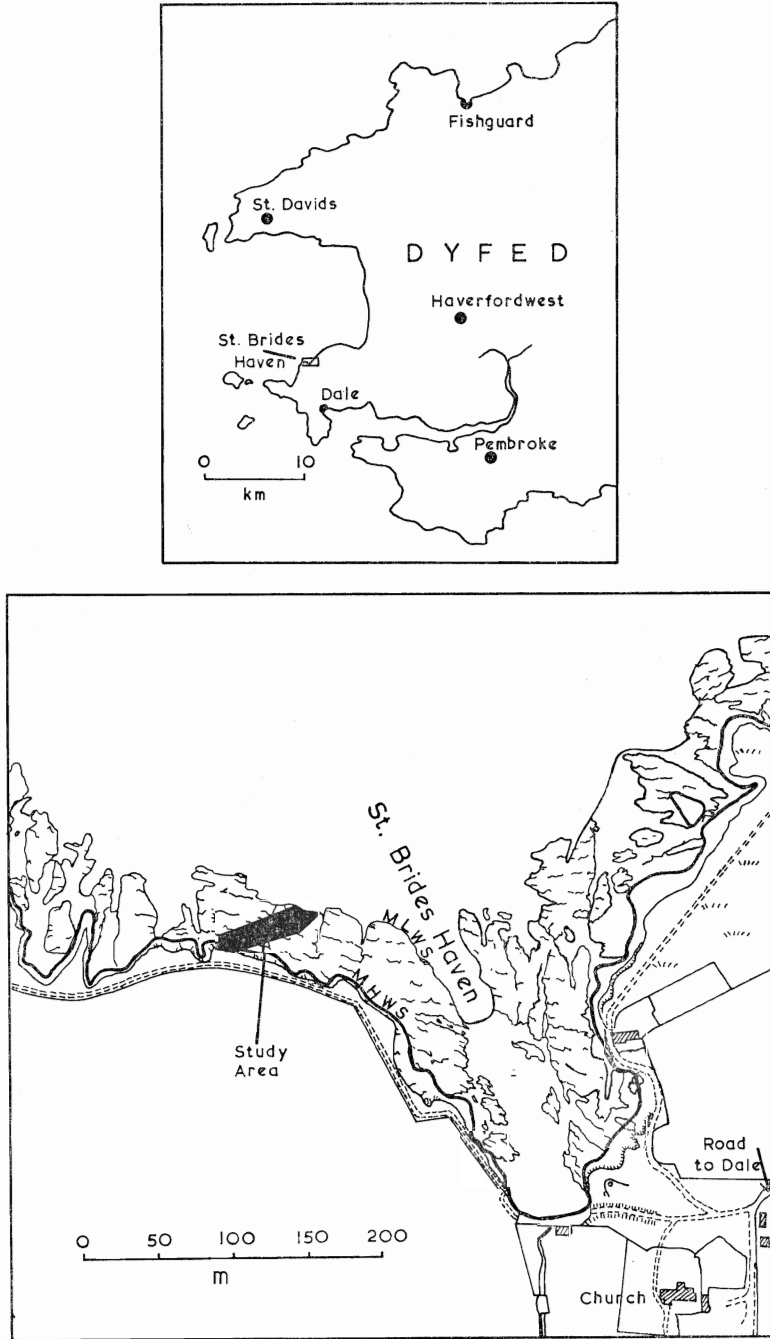

FIG. 1.  
The location of St. Bride's Haven (upper map) and the position within the Haven of the study area (lower map).

## 2. Methods

(i) Temperature was measured with a Grant thermistor thermometer, equipped with six probes, each connected to the instrument by an extension lead of approximately 5 m. This facilitated simultaneous monitoring of different pools and also various positions within pools, with the instrument remaining at a central point. The accuracy of temperature measurement was  $\pm 0.1$  °C.

(ii) Salinities were determined either directly using a salinity/temperature measuring bridge type N.C.5. (Electronic Switchgear Ltd.), or by conversion from chlorinity determined by a standard silver nitrate (Mohr) titration. 10 cm<sup>3</sup> of sea water were titrated against silver nitrate solution (9.577 g/l) using 8–12 drops of potassium chromate solution (8 g/100 ml) as an indicator. 1 cm<sup>3</sup> of silver nitrate solution is equivalent to 2 mg of chloride.

(iii) pH was measured using a Unicam portable pH meter (Model 293) with an accuracy of  $\pm 0.1$  units.

(iv) Carbon dioxide was measured by the method of Strickland and Parsons (1968). The association of CO<sub>2</sub> and seawater is complex (Harvey, 1945; Raymont, 1963). As the gas dissolves in sea water the following reaction occurs:



Carbonic acid (H<sub>2</sub>CO<sub>3</sub>) forms after the addition of CO<sub>2</sub> to sea water. The presence in sea water of excess bases which react with H<sup>+</sup> causes the reaction to proceed to the right and bicarbonate (HCO<sub>3</sub><sup>-</sup>) accumulates. The amount of HCO<sub>3</sub><sup>-</sup> accumulated is proportional to the CO<sub>2</sub> dissolved. According to Harvey (1955), 99 per cent of the CO<sub>2</sub> dissolved in sea water is in this form. The term "total-alkalinity" represents the HCO<sub>3</sub><sup>-</sup> present together with the other buffer bases. As this latter component is a constant, the alkalinity due to HCO<sub>3</sub><sup>-</sup> can be calculated and is a measure of the CO<sub>2</sub> in the water.

To estimate the HCO<sub>3</sub><sup>-</sup>, the pH of 100 ml of pool water was measured before and after the addition of 25 ml of 0.02 N HCl. The magnitude of the fall in pH represents the number of H<sup>+</sup> derived from the HCl which remained unbuffered by the HCO<sub>3</sub><sup>-</sup> present. A relatively small drop in pH would therefore indicate high levels of bicarbonate.

By reference to tables (Strickland and Parsons, 1968) it is possible to determine the amount of bicarbonate alkalinity and hence the volume of CO<sub>2</sub> dissolved in the water.

(v) Oxygen was determined by the Winkler technique. The principle of the method is described in numerous practical texts. Samples were collected in 30 cm<sup>3</sup> glass bottles with ground glass stoppers bevelled to prevent the trapping of air bubbles (Hoar and Hickman, 1967). A method was devised to localize exactly the sampling position and to minimize water disturbance. The sampling apparatus, shown in Fig. 2, consisted of sample bottle (B), rubber teat (Pasteur pipette type) (T), length of polythene tubing, spring clip and metre rule. The lowermost few millimetres of a rubber teat were cut away to achieve a close fit into the top of the sample bottle. A small hole (H1) was cut at the top of the teat and a piece of thin polythene tubing (3–4 mm inside diameter, and 1.5 m long) was inserted such that the leading end was flush with the cut edge at the base of the teat. Finally, another small hole

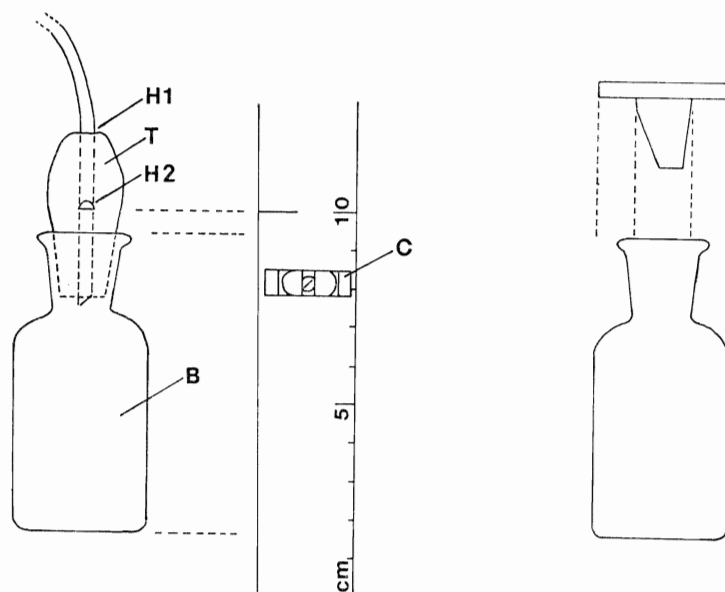

FIG. 2.  
Apparatus for obtaining samples for the determination of oxygen concentration.  
Refer to text for explanation of lettering.

(3–4 mm) (H2), was cut into the side of the teat slightly above the level of the bottle top, through this hole the sample entered the bottle. The bottle was clipped to the metre rule by a Terry clip (C).

In use, the free end of the polythene tubing was gripped between the teeth whilst the bottle was lowered to the desired depth within the pool (as read from the metre rule). No water entered the bottle until pressure on the polythene tube was released. Water then flowed through the aperture in the side of the teat into the bottle, whilst air contained within the bottle escaped through the tube. Thus the pool water column was not disturbed by air bubbles. When the bottle was full the apparatus was removed from the pool and the bottle unclipped, air was excluded by tilting the bottle and sealing with the bevelled stopper. Using 2 cm<sup>3</sup> “disposable” hypodermic syringes and needles, 0.3 cm<sup>3</sup> of manganous sulphate solution (480 g MnSO<sub>4</sub>·4H<sub>2</sub>O/l) followed by the same volume of sodium hydroxide/potassium iodide solution (500 g NaOH: 150 g KI) were added in rapid succession to the middle of the sample, and the bevelled stopper replaced. Approximately 15 minutes were allowed for the precipitate to consolidate. The iodine was then released from the precipitate by the addition of 0.3 cm<sup>3</sup> of concentrated sulphuric acid from a dropping bottle pipette. The bottles were then placed in darkness.

In the laboratory, a 20 cm<sup>3</sup> sample was pipetted into a conical flask. Using a few drops of 0.1 per cent starch solution as an indicator, the iodine was titrated against 0.01 N, or 0.001 N sodium thiosulphate from a 5 cm<sup>3</sup> microburette. The latter concentration was used when oxygen levels fell below approximately 2 mg O<sub>2</sub>/l. With experience this could be deduced from the intensity of the brown colour of the released iodine. Oxygen concentrations are expressed as mg/l and as percentage of theoretical maximum saturation, determined by interpolation from graphs drawn from data supplied in the *Handbook of Biological Data* (Spector, 1956).

The accuracy of titration was checked by the replicate analysis of a single sea water sample. Ten separate determinations with 0.01 N sodium thiosulphate, for oxygen content of a normal sea-water sample, gave a mean and standard deviation of 7.90 mg O<sub>2</sub>/l ± 0.09 (range 7.96–7.85 mg O<sub>2</sub>/l). A second deoxygenated sea-water sample, upon which eight analyses were made using 0.001 N sodium thio-sulphate, gave a mean and standard deviation of 1.00 mg O<sub>2</sub>/l ± 0.03 (range 1.02–0.98 mg O<sub>2</sub>/l).

(vi) Volume of pools. A dilution technique was devised to determine pool volumes on the final day of field work. After thorough mixing, the salinity of each pool (S<sub>1</sub>) was measured using the salinometer. A known quantity of sodium chloride was then added, the pool again very thoroughly mixed and the salinity redetermined (S<sub>2</sub>). Volume was assessed from the increase in salinity as follows:

$$\text{volume of pool (l)} = \frac{\text{weight of NaCl added (gm)}}{\text{salinity increase (\%)}} \\ (S_2 - S_1)$$

In practice, various amounts of NaCl were pre-weighed in the laboratory, the pool volume assessed subjectively and a quantity of NaCl (50–500 gm) added to raise the salinity by between 2–4 ‰.

#### *Procedure at Pool Sides*

As the tide went out temperature probes were placed in each pool at a selected sampling position, then from a central location, pool temperatures were recorded at hourly intervals. From a position 6 cm below the surface near the centre of each pool a 30 cm<sup>3</sup> water sample was removed every hour for determination of oxygen content. Samples for determination of salinity, pH, and carbon dioxide were collected in 250 cm<sup>3</sup> screw topped polythene containers near the end of the exposure period. The pH and temperature were measured immediately, whilst the others were determined later in the laboratory.

Measurement of diurnal fluctuation in temperature and oxygen concentrations with depth were made in a deep mid-tide pool adjacent to pool 4. Temperature/depth profiles were obtained using six thermometer probes attached at intervals by elastic bands to the vertically positioned metre rule. Water samples for oxygen determinations were taken from selected depths.

#### *Pool Characters*

Six pools (pool 1 the highest, pool 6 the lowest) were chosen, varying in shore height, aspect, surface area and depth, and inevitably, with different numbers and proportions of plants and animals living in them. The relative position of these pools on the shore is shown in Fig. 3 together with brief physical and biological features in Table 1. The pools are also shown in Plates 1–6. Certain of the pools (2 and 3, and to a lesser extent 4 and 6) were studied to compare the influence of aspect upon adjacent, essentially very similar pools. Pools 2, 3, 4 and 6 contained abundant seaweeds which were not present in pools 1 and 5. The rock surface in pool 1, however, was covered by blue-green algae and in 5 encrusted with *Lithothamnion* sp.

Table 1. Basic physical and biological features of the six pools under study

	POOL 1	POOL 2	POOL 3	POOL 4	POOL 5	POOL 6
<b>Physical features</b>	Small, shallow, high shore, above M.H.W.N. exposed to sun.	Medium sized, shallow high shore, near M.H.W.N., shaded.	Medium sized, shallow, high shore, near M.H.W.N., exposed to sun.	Medium to large size, deep, middle shore, surface exposed to sun, deeper parts shaded by algae.	Small, very shallow with large surface area relative to depth. Middle to low shore, above M.L.W.N. exposed to sun.	Small, shallow, low shore, near M.L.W.N. shaded.
Height above chart datum (m)	5.50	4.86	4.90	3.87	3.02	2.41
Volume (l)	20.0	112.0	125.0	385.0	23.0	33.0
Maximum depth (m)	0.14	0.20	0.26	0.57	0.09	0.26
Surface area (m <sup>2</sup> )	2.07	3.90	1.99	1.76	2.23	0.32
Surface area/maximum depth	14.8	19.5	7.6	3.1	24.8	1.2
<b>Biological features</b>	Rock surface encrusted with inconspicuous blue green algae, no large plants. Few animal species, biomass small. Dominant animal species, <i>Tigriopus brevicornis</i> (O. F. Muller) (copepoda) <i>Littorina saxatilis</i> (olivi).	Heavily weeded, green algae <i>Enteromorpha</i> sp. dominant. Animal and plant species more numerous than pool 1 with greater biomass. Dominant animals, <i>Littorina littorea</i> (L.), <i>Palaeomon elegans</i> Rathke.	Similar appearance to pool 2. Fewer animal species but biomass similar. Dominant animals, <i>Littorina littorea</i> , <i>Palaeomon elegans</i> .	Heavily weeded, red algae present, brown algae dominant. High diversity and abundance of animals and plants.	No large plants, surface encrusted with calcareous algae <i>Lithothamnion</i> sp. Animal species few but abundant. Dominant animals, <i>Patella aspera</i> Lamarck, <i>Actinia equina</i> L. and <i>Balanus</i> sps.	High ratio of plant biomass to volume. Dominant algae, <i>Laminaria</i> sps. and <i>Coralina officinalis</i> L. Few animal species, <i>Patella aspera</i> and <i>Sagartia troglodytes</i> (Price) most abundant.

PLATES 1-6.

The rockpools investigated in this study. Scale is indicated by a metre rule.

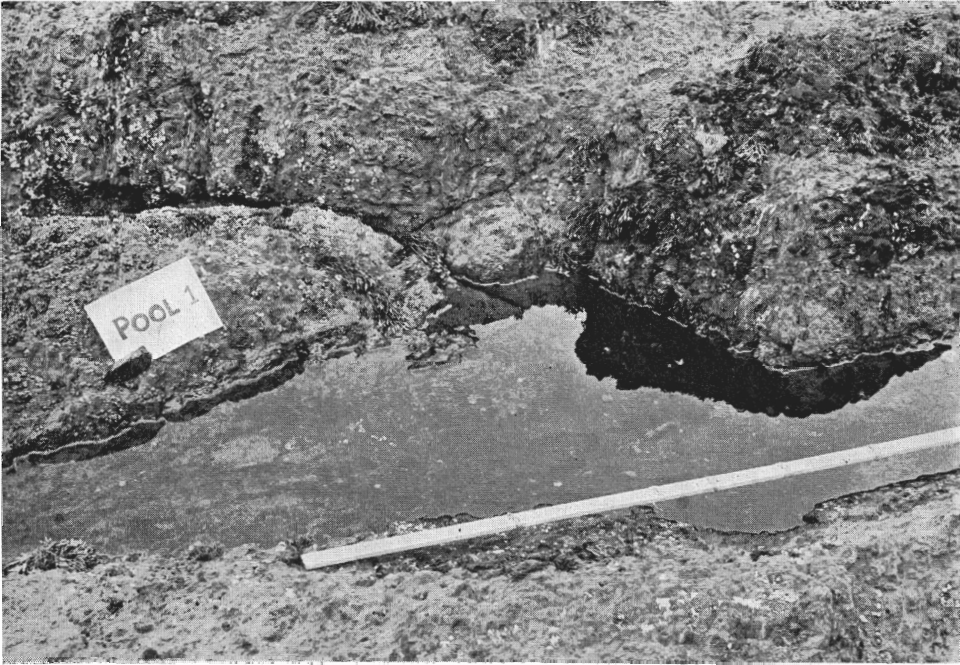

PLATE 1.

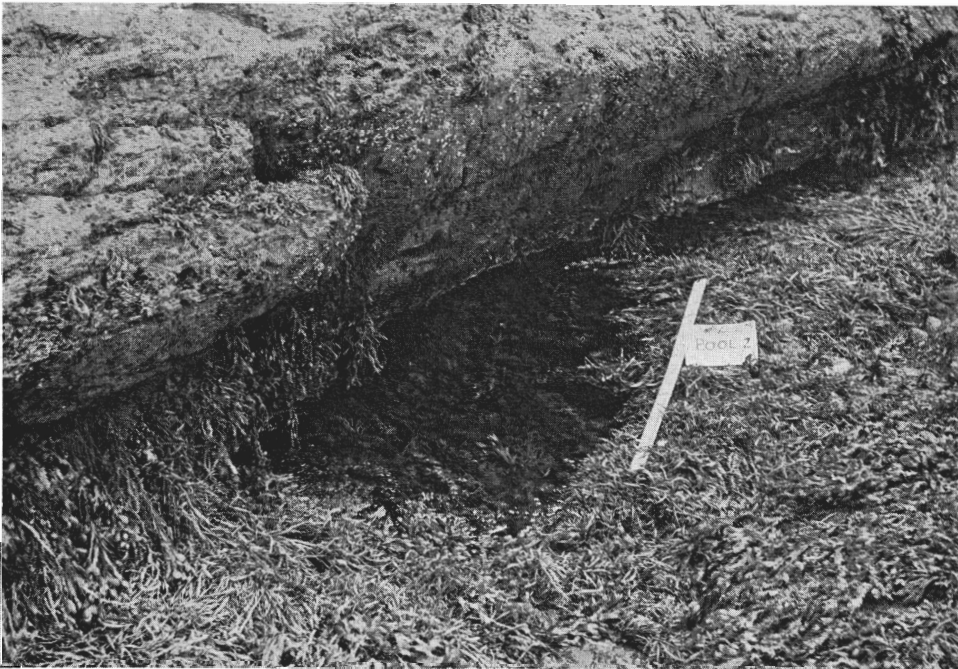

PLATE 2.

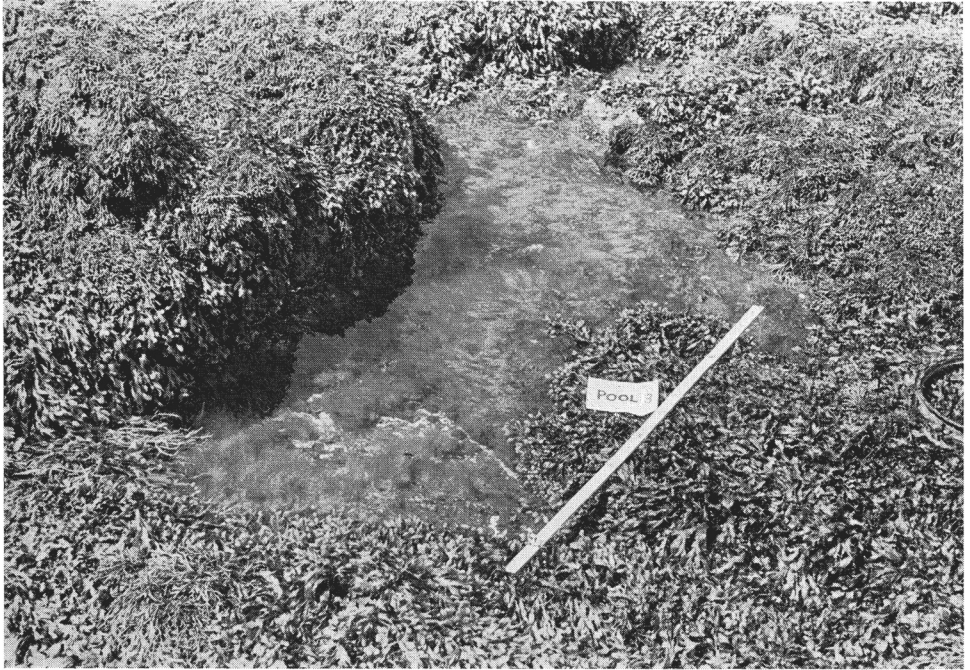

PLATE 3.

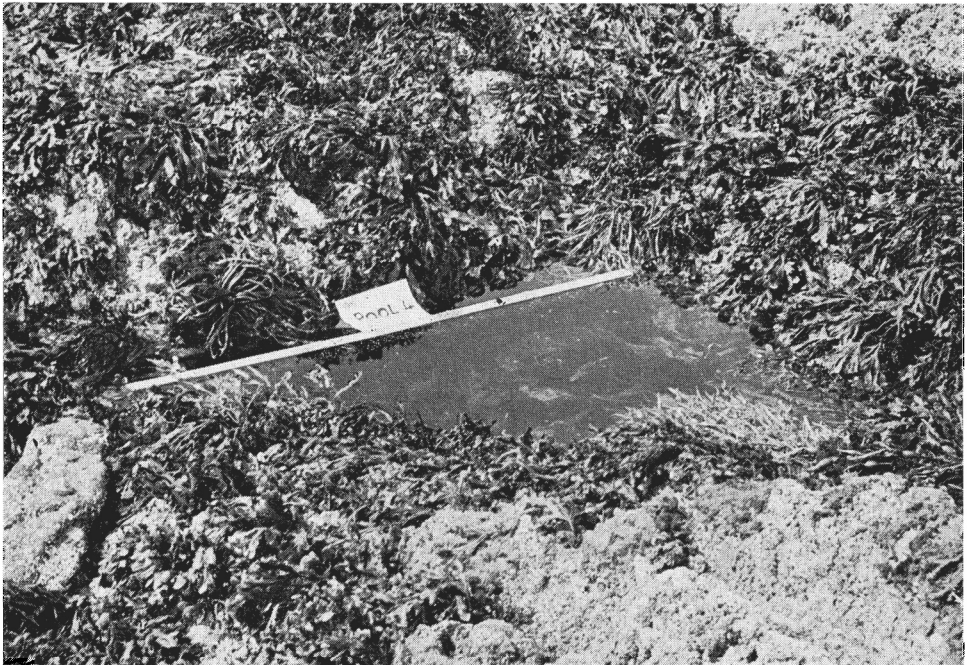

PLATE 4.



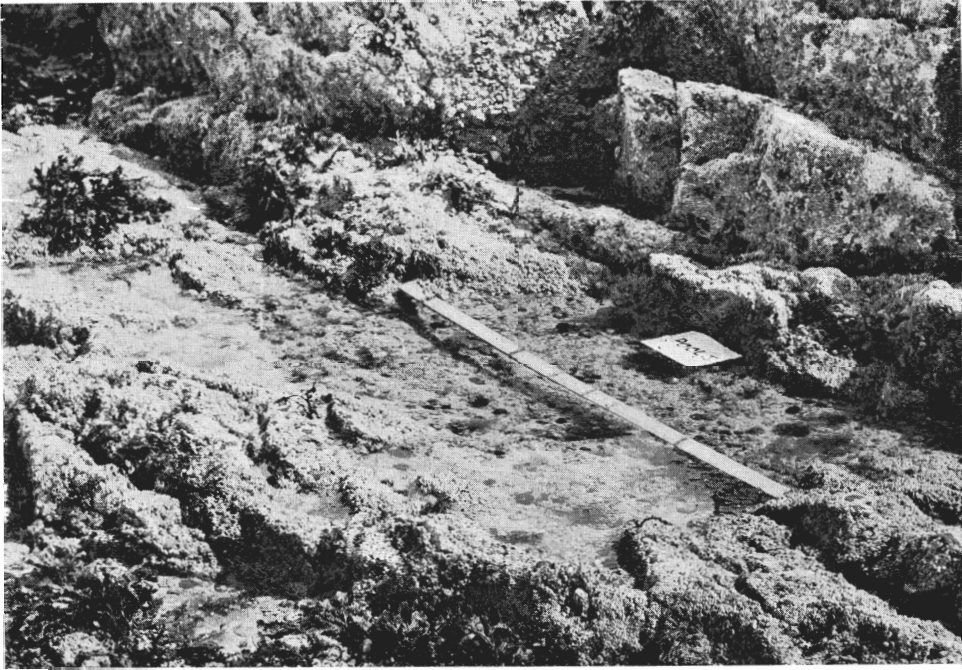

PLATE 5.

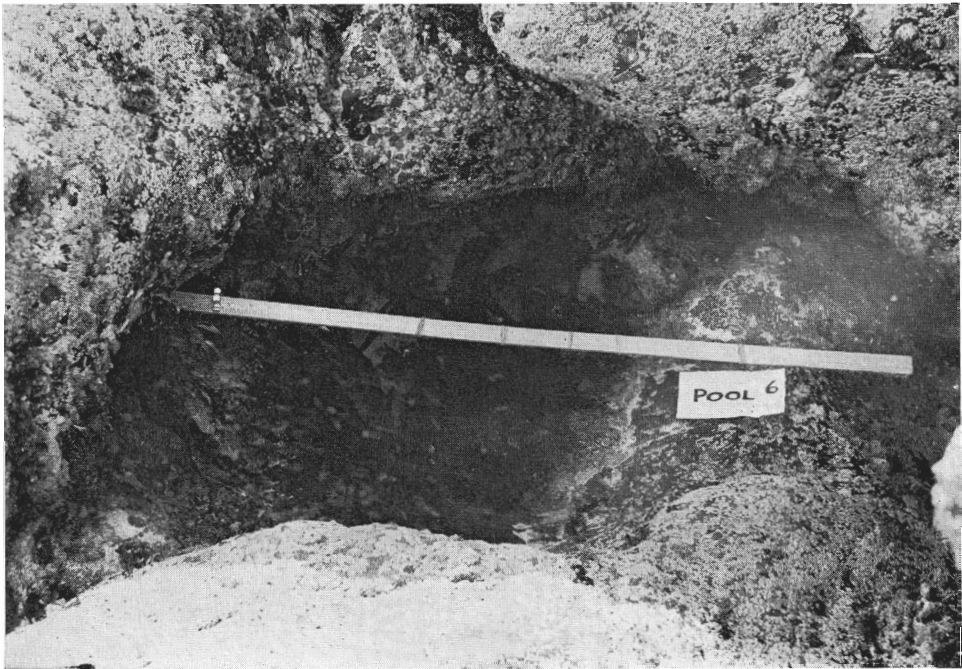

PLATE 6.

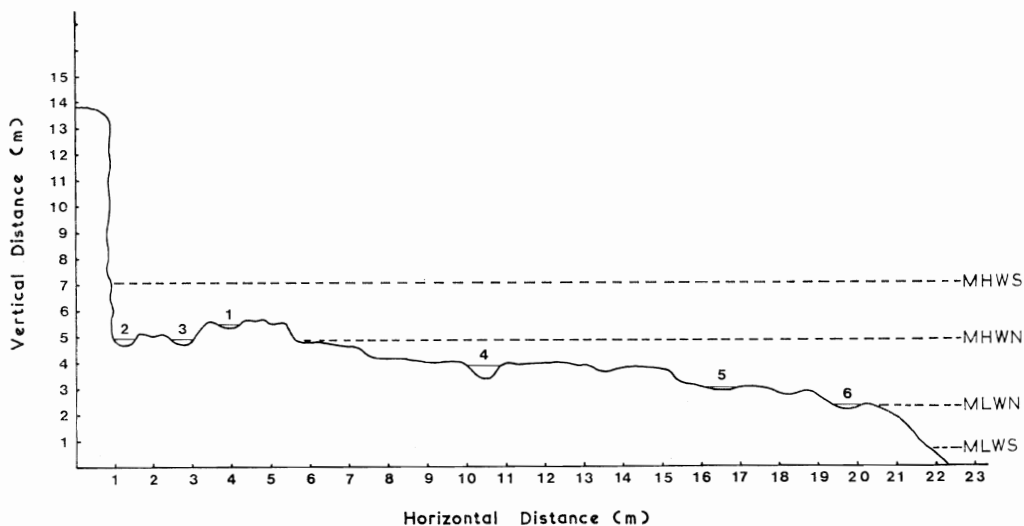

FIG. 3.

Diagrammatic representation of the shore profile at St. Bride's Haven. Numbers refer to the rock pools under study.

## RESULTS

### 1. Variation in Temperature and Oxygen Within Single Pools

A temperature/oxygen profile with depth in a large mid-tidal pool (Fig. 4) shows clearly that during the day the body of pool water is far from homogeneous. Temperature at the pool bottom was  $7.5^{\circ}\text{C}$  lower than at the surface. Oxygen likewise showed marked stratification, but unlike temperature, the maximum level of  $19.1\text{ mg O}_2/\text{l}$ , 225 per cent saturation, was found some 10 cm below the pool surface. In the same pool at night both oxygen and temperature were considerably lower, and in the central column at least there was little evidence of stratification, which, as Table 3 shows, does occur to some extent near the margins of the pools; samples from these sites were always more depleted in oxygen than those taken from clear water in the pool centre.

### 2. Diurnal Variation of Physico-Chemical Conditions in Rockpools

Graphs of temperature and oxygen changes for each of the pools are shown in Fig. 5. In pools exposed to the sun, a marked increase in temperature reached a maximum in the afternoon (14.00–15.00). This change was greatest in pool 1 in which temperature rose to  $11^{\circ}\text{C}$  above that of the sea. In shaded pools the change was much smaller, less than  $1^{\circ}\text{C}$  in pool 2. At night, sea, air, and consequently pool, temperatures were almost the same.

As is clear from Table 2 and Fig. 5, all pools during the day become supersaturated with oxygen, the process again reaching a peak in the afternoon. Like temperature, oxygen concentrations fell in the latter part of the afternoon, nevertheless all remained supersaturated until the return of the sea. Oxygenation was most marked in pool 3 in which concentrations as high as  $21.5\text{ mg O}_2/\text{l}$ , over 300 per cent saturation, were recorded (Table 3). Unlike the pattern of temperature change,

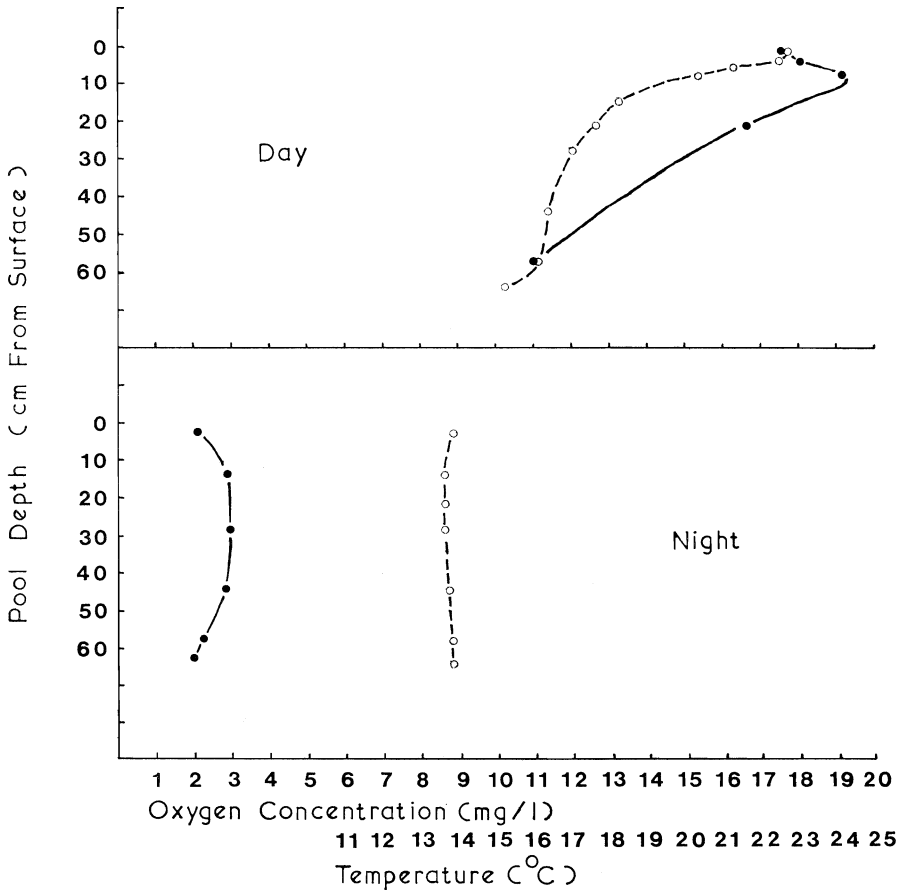

FIG. 4.

The profiles of oxygen (●—●) and temperature (○—○) with depth in the central column of a large mid-tidal rockpool exposed by day and night.

however, oxygen rise was also marked in shaded pools. At night, following the fall of the tide, a progressive reduction in oxygen tension was recorded in all pools. The lowest concentration measured was 0.27 mg O<sub>2</sub>/l, 3 per cent saturation, in pool 3. Deoxygenation proceeded at first relatively rapidly but later more slowly. From dawn (at approximately 04.45) oxygen concentration increased only little in the high shore pools until they were again flooded by the sea.

During the day, carbon dioxide concentration fell and pH levels rose (Table 2). After maximum exposure the changes were greatest in pool 3, a rise of 1.7 pH units and a fall of 66 mg CO<sub>2</sub>/l, and least in pool 6, a rise of 0.25 pH units and a fall of 22.7 mg CO<sub>2</sub>/l. At night the direction of change was reversed, carbon dioxide increased and pH fell in all pools. The magnitude of change was smaller than during the day, the maximum being 0.75 pH units and 19.4 mg CO<sub>2</sub>/l.

Changes in salinity were very small (Table 2). Even in the extreme case in pool 1 after nearly nine hours exposure to the sun, salinity rose by only 1.3 ‰. At night changes in salinity were undetectable.

Table 2 Physico-chemical conditions within rock pools after maximum exposure\*

Pool number	DAY (30/7/73)						NIGHT (31/7/73-1/8/73)									
	Ex <sub>1</sub> † hr. min.	Ex <sub>2</sub> † hr. min.	Temp. °C	Salinity ‰	pH	CO <sub>2</sub> mg/l	O <sub>2</sub> mg/l	O <sub>2</sub> Saturation %	Ex <sub>1</sub> hr. min.	Ex <sub>2</sub> hr. min.	Temp. °C	Salinity ‰	pH	CO <sub>2</sub> mg/l	O <sub>2</sub> mg/l	O <sub>2</sub> Saturation %
1	9.30	8.45	24.8	34.07	8.90	65.1	13.92	196	9.35	9.00	14.5	32.79	7.70	104.9	3.78	44
2	9.15	8.40	14.4	32.52	8.65	69.8	17.36	203	8.50	8.20	13.6	32.75	7.30	101.3	1.65	19
3	9.15	8.40	20.8	32.72	9.50	30.8	19.16	250	8.50	8.25	13.8	32.79	7.20	107.6	1.07	12
4	7.50	7.45	21.3	32.87	8.30	84.7	15.56	204	7.20	7.13	14.0	32.79	7.40	104.9	0.72	8
5	5.45	5.05	24.0	33.30	8.70	60.6	14.08	194	5.55	5.43	13.1	32.79	7.50	110.7	2.32	27
6	4.45	4.25	14.7	32.60	8.45	74.3	10.17	119	4.45	4.39	14.0	32.79	7.45	—	3.82	44
Sea water	—	—	15.6	32.79	8.20§	97.0	9.58	114	—	—	13.9	32.79	8.05‡	91.3	6.32	73

\* Temperature and oxygen, which were measured throughout the exposed period, did not necessarily show the maximum change at this time; for these data refer to fig. 5.

† Ex<sub>1</sub>: Total length of exposure of pool in hours and minutes.

‡ Ex<sub>2</sub>: Length of exposure of pool at sampling time in hours and minutes.

§ Recorded on subsequent day; sea temperature 14.1 °C.

§ Recorded on subsequent day; sea temperature 13.5 °C.

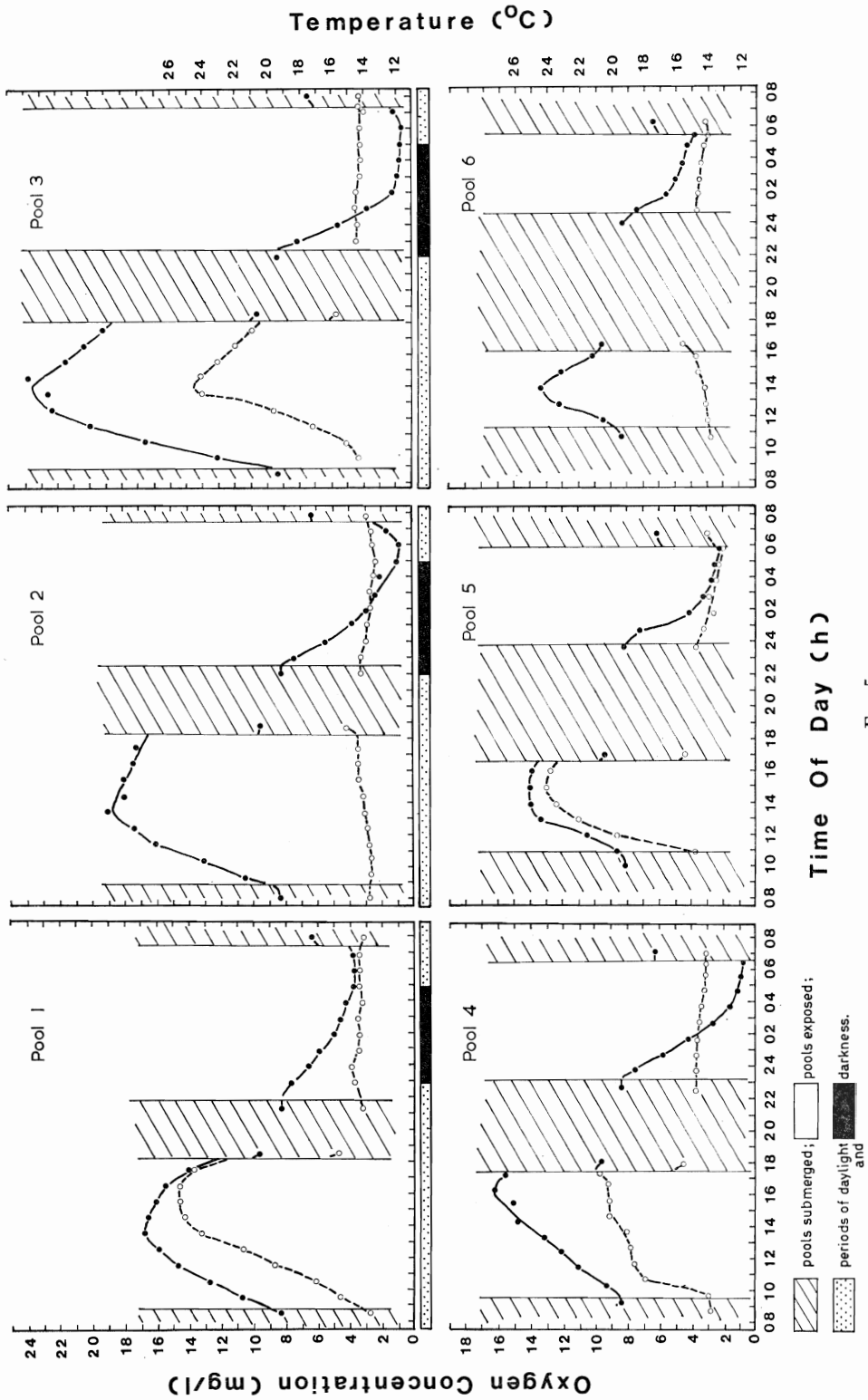

Fig. 5. Diurnal variation in oxygen concentration (●—●) and temperature (○—○) in the six pools under study.

Table 3. Diurnal variation in temperature, oxygen and pH between and within several pools

Pool No.	DAY (31.7.73)						NIGHT (1.8.73-2.8.72)				
	Ex*	Sample site	Temp °C	pH	O <sub>2</sub> mg/l	Sat. %	Ex*	Temp °C	pH	O <sub>2</sub> mg/l	Sat. %
2	7.00	PM	15.5	—	22.75	283	6.30	13.6	—	0.79	9.2
		PC	15.1	8.50	17.85	211		13.6	7.30	0.97	11.2
3	7.00	PM	24.9	—	21.55	301	6.30	13.7	—	0.27	3.1
		PC	23.8	9.40	20.28	279		13.7	7.2	0.45	5.2
4	5.00	PM	20.4	—	19.56	254	4.30	13.9	—	0.90	10.4
		PC	20.5	8.50	16.20	210		13.9	7.40	1.06	11.8

Ex\* = Length of exposure of pool at sampling time (hours and minutes).

PM = Pool margin, within algal fringe.

PC = Clear water in pool centre.

### DISCUSSION

Considerable variation in physico-chemical conditions may occur within pools (Fig. 4 and Table 3). To enable comparison between pools standard sampling procedures should be employed, permitting samples to be taken discreetly and with minimum disruption to strata within each pool. On sunny days, stratification of temperature and oxygen and presumably other metabolically dependent factors, carbon dioxide and pH, readily occurs, particularly in the deeper pools. On overcast or particularly windy days, however, the effect may be much less, whilst at night stratification is considerably reduced and probably restricted to the pool margins (Table 3).

Rockpool temperature is related to physical features such as volume, depth, surface area and aspect, but primarily dictated by the amount of direct sunlight. Within limits the period of exposure is much less important. Thus, despite differing exposure times, the 10 °C increase found during the day in the low shore pool 5 is much the same as that found in the high shore pools 1 and 3. Similarly, the temperatures of high shore pool 2 and low shore pool 6, both of which were shaded, varied by only 1 °C.

The importance of direct sunlight is well illustrated in a comparison between pools 2 and 3. The temperature of the unshaded pool 3 rose rapidly during the morning to a maximum of 25 °C, a rise of some 11 °C. In contrast, the shaded pool 2 rose by only 1 °C, despite air temperatures of 20 °C, probably due to the low temperature of the bedrock, which by acting as a heat sink, conducts any gained heat away from the pool. This, together with reduction of insolation, also accounts for the marked temperature drop of sunlight pools in the late afternoon. Similar maximum diurnal variations of 10–11 °C were observed in Baltic rockpools by Ganning (1971), who pointed out that even tropical pools showed no greater magnitude of diurnal fluctuation.

At night, pool temperatures are determined by the temperatures of the ebbing sea, bedrock (which would be similar to the sea) and the air. Our night-time pool temperatures remained almost constant at 14 °C, a reflection of the almost identical

air and sea temperatures. Bearing in mind the buffering effect of the bedrock on temperature, it is likely that during exposure on overcast days and at other seasons of the year, the temperatures of rock pools will change only slowly in the direction of air temperature.

Pool oxygen, carbon dioxide and pH are closely linked with respiration and photosynthesis, the rates of which are primarily determined by temperature and illumination. The extent to which concentrations of gases in the water are altered as a result will depend on the amounts and relative proportions of animals and plants, and such physical features as depth and surface area. These physical features influence the rate of diffusion at the pool surface. Measurements of oxygen concentrations made when the pool is supersaturated will underestimate oxygen production, as a diffusion gradient directs oxygen out of the water. Similarly, when the water is deoxygenated the extent of oxygen consumption will be underestimated because of diffusion into the pool. Carbon dioxide concentration on the other hand may be more useful for determining rates of pool metabolism because exchange with the atmosphere is slow (Raymont, 1963) and calculations are consequently not complicated by corrections for diffusion. The advantage of carbon dioxide is unfortunately offset by the difficulty in obtaining reliable measurements.

As anticipated, oxygen, carbon dioxide and pH changes by day were greatest in well illuminated pools containing large quantities of algae. Maximum diurnal variation of oxygen, 300 per cent saturation by day and 3 per cent saturation by night, found in pool 3 is similar to extremes reported elsewhere and reviewed by Ganning (1971). The lowest level of 3 per cent oxygen saturation ( $0.2 \text{ mg O}_2/\text{l}$ ), also recorded by Ganning in certain Baltic pools, is probably a minimum for small, free standing bodies of water un-enriched by decaying organic material.

Despite the much lower daytime temperature and greatly reduced level of illumination in pool 2, compared with pool 3, there was nevertheless a very considerable increase in oxygen even in this shaded pool ( $19 \text{ mg O}_2/\text{l}$ , 220 per cent saturation). There are two reasons why changes in shaded pools may approach those in adjacent sunlit pools. Firstly, although increase in temperature raises the rate of photosynthesis it also increases respiration and does so proportionately more quickly. The  $Q_{10}$  (increase in rate of reaction for a  $10^\circ \text{C}$  rise in temperature) is 1.5 for photosynthesis but between 2 and 3 for respiration (Hoar, 1966). Thus at high temperatures as in pool 3, although production of oxygen by photosynthesis considerably exceeds demand, the high respiratory uptake by both animals and plants offsets some of this increase. The second factor is that as oxygen saturation rises, the gradient favouring oxygen loss by diffusion to the atmosphere will also increase. In addition, as temperature increases, the capacity of the water to hold oxygen becomes reduced. At the temperature of pool 3 and 2,  $24^\circ \text{C}$  and  $14^\circ \text{C}$ , the oxygen concentration at 100 per cent saturation is  $7.28$  and  $8.62 \text{ mg O}_2/\text{l}$  respectively. The result of these factors is that the greater the supersaturation the larger will be the loss of oxygen from the pool; indeed, in pool 3 especially, much of the oxygen produced by the plants was visible as free bubbles.

Although oxygen measurements cannot provide direct quantitative comparisons of photosynthesis in different pools, carbon dioxide measurements, for the reasons given previously, are probably a better guide. Thus carbon dioxide in pool 3 decreased from  $97 \text{ mg/l}$  to  $31 \text{ mg/l}$ , a reduction of  $66 \text{ mg/l}$ , whilst in pool 2 the change was only  $27 \text{ mg/l}$  (Table 2). Even neglecting the relatively greater produc-

tion of carbon dioxide associated with respiration in pool 3, these data make it clear that photosynthesis in this pool was over double that of pool 2.

The other pools with large sea weeds, 4 and 6, did not reach such high oxygen saturation levels as the two high shore pools, although, in pool 4 particularly, the supersaturation by day and depletion by night was still considerable (Fig. 5 and Table 2). Interestingly, the peak of oxygen tension in pool 4 was reached later than the other pools. This may well reflect the plant population, mainly brown and red algae. Such plants would be expected to have a photosynthetic optimum at lower light intensities than the green algae in upper shore pools. Such an effect is well known for terrestrial shade and light loving plants (Böhning and Burnside, 1956) and has been noted for supra-littoral pools containing on the one hand planktonic algae and on the other macrophytes, *Enteromorpha* sp. (Ganning and Wulff, 1970). Despite containing similar algae, the oxygen peak in pool 6 was earlier than in pool 4, probably reflecting the heavily shaded position of pool 6 in which optimum light intensity would have been reached earlier.

Absence of macrophytes from pools 1 and 5 did not, however, prevent considerable increases in oxygen during the day (Fig. 5 and Table 2). The relatively inconspicuous blue-green algae and *Rivularia* sp. of pool 1 and *Lithothamnion* sp. in pool 5 are deceptive in this respect. Respiratory levels must have been particularly high in pool 5 which contained many animals. Consequently, during the day the oxygen concentration in pool 5 did not rise as high as in pool 1, but at night the higher respiratory demand in pool 5 ensured that deoxygenation was more complete. Pool 5 was also shallow, with, therefore, proportionately large surface area. Nevertheless, oxygen saturation showed a diurnal variation of between 193 per cent and 23 per cent, indicating relative slow movement towards equilibrium between pool oxygen and the atmosphere.

Changes in oxygen and carbon dioxide tensions at night are easier to interpret than daytime measurements as they are due solely to respiration. For practical purposes temperature was constant and so therefore we assume was also the rate of respiration, at least down to very low oxygen tensions, which might inhibit respiration. The slope of the initial portion of the night oxygen graphs in Fig. 5 allows comparisons to be made between the respiratory demands within the various pools (Table 4). It is steepest, and hence respiration greatest, in pools 3, 5 and 6 which is in keeping with the biomass observations. Highest carbon dioxide concentration at night were also from pools 3 and 5 (Table 2). Pool 1 has a particularly shallow slope which reflects its sparse flora and fauna, while pools 2 and 4 have intermediate slopes.

Salinity changes were generally small, with the greatest effect in the small high shore, sunlit pool 1. The increase in salinity over a single daytime exposure was modest, 1.3 ‰, representing an evaporation of 0.6 l of water or 3 per cent of the total pool volume. High shore rockpools are not, however, refreshed at every tide.

Table 4. *Estimated night-time oxygen consumption of pools 1-6*

	Pool No.					
	1	2	3	4	5	6
Oxygen consumption (mg O <sub>2</sub> /l/h)	0.95	2.04	2.67	1.68	2.75	2.66



According to tidal predictions, pool 1 would have been above high water mark for four days during the week after we finished work. If the weather had not changed by then, salinity would increase by up to 5.2 ‰. Salinity tolerances of high shore rockpool organisms are generally much higher than this. *Gammarus duebeni* Liljeborg for example has an upper salinity tolerance of 73 ‰ (Ganning, 1971), and the copepod *Tigriopus brevicornis* normally tolerates salinities of between 4.3 and 90 ‰ and will recover from even higher concentrations (Ranade, 1957). Heavy rain does not affect salinity very much. Pyefinch (1943) found significant variation only in the surface waters of upper shore pools; those lower on the shore were virtually unaffected. Ganning (1971) claims that, even for supra-littoral pools in which the greatest changes occur, the ecological importance of salinity variation has been overestimated.

Ecologically, the most important physico-chemical factors appear to be temperature and those largely determined by the organisms themselves, oxygen, carbon dioxide and pH. Although many measurements of rock pool pH have been made (for review see Ganning, 1971), the direct effect of varying  $H^+$  concentration on organisms is largely unknown. This is also true for carbon dioxide. Although the capacity of sea water to hold and release this gas is so great, it is unlikely ever to be a limiting factor of photosynthesis or respiration. On the other hand, temperature and oxygen concentration, both of which are liable to considerable diurnal variation, have important ecological significance. Klugh (1924) and Stephenson, Zoond and Eyre (1934) considered temperature to be one of the most important, if not the most important, factor determining the variety of rock pool organisms. Ganning (1971) concurred, citing experiments to show that swimming activity, metabolism, and connected problems such as time of development are to a great extent ruled by water temperature.

At first sight, the greatest influence by oxygen would be expected at night when very low tensions are recorded. This overlooks the inhibitory effect that oxygen may have at the high concentrations recorded during the day. Prosser (1967) cites various instances and Ganning (1967) has shown that certain rock pool ostracods, e.g. *Heterocypris salinus* (Brady), tolerated water of low oxygen concentration (18–25 per cent saturation) better than either hyperoxygenated water (338–353 per cent saturation) or even air bubbled water (97–105 per cent saturation). Even so, the very low tensions at night must exert a considerable influence. Ganning (1971) reports the migration of various species of ostracods, the snail *Lymnea peregra* (Muller), and *Gammarus duebeni* to the surface at night. Similarly, we observed that in the high shore pools 2 and 3 at night, the population of prawns, *Palaemon elegans* gathered around the very edge of the pool, presumably taking advantage of the better oxygenated surface layer. The majority of shore-crabs, *Carcinus maenas* (L.), leave the pools completely at night and most are then in crevices or amongst the algae. Those animals which can air-breathe have the advantage of being able to leave the pool at night; as well as shore-crabs (Newell et al., 1972; Taylor and Butler, 1973), winkles, *Littorina* sps. (Sandison, cited in Lewis, 1964), limpets, *Patella* sp. (Davies, 1966) and the blenny, *Blennius pholis* L. (Daniel, 1971) can do so. The lack of sedentary animals, most notably barnacles, in many rock pools may reflect the inability of settling larvae to survive the large diurnal fluxes of oxygen.

Pool 4 illustrates the movement of sublittoral species into the littoral zone (Lewis, 1964). At first sight a part of the sub-littoral, this relatively large and deep pool

experiences considerable diurnal changes (Fig. 5 and Table 2); many normally sub-littoral species may be more tolerant of variations than is usually accepted. Indeed, the sea in the sub-littoral fringe is not without variation; samples were 114 per cent saturated with oxygen during the day and 73 per cent saturated at night, reflecting the metabolic activity of the fringing kelp beds. Different algae have differing optimum light conditions for photosynthesis. Perhaps hyper-illumination is a primary limitation on the upshore spread of sub-littoral algae into rock pools.

Some low shore species are clearly extremely tolerant of physico-chemical change, a notable example being the limpet *Patella aspera* Lamark which is often found in large numbers in pools high into the mid littoral. Generally, however, communities in pools above mid-tidal level are very different from those of the sub-littoral fringe, with generally fewer and more specialized species. Physico-chemical conditions, particularly temperature and oxygen, play an important role in determining distributions.

At St. Bride's Haven, the low water of spring tides occurs around midday and midnight. At other localities, e.g. North Wales, spring lows are in the evening and early morning; if measurements were made in pools on those other shores with different tidal patterns, the diurnal changes would differ from those we measured at St. Bride's. Less extreme variations are likely, particularly in the lower shore pools, which may facilitate greater uplift of sub-littoral species into mid-tidal pools.

#### ACKNOWLEDGEMENTS

We are grateful to Mr. D. Emerson and to Mr. P. Hunnam for facilities and encouragement at Dale Fort. Miss C. Lineham and Mr. A. Smith, among many Derby students, helped to develop the methods we used. Our thanks are also due to Mr. M. Wignall who drafted Fig. 2 and to Mrs. P. Comber for typing the manuscript.

#### BIBLIOGRAPHY

- BALLANTINE, W. J. (1961). A biologically-defined exposure scale for the comparative description of rocky shores. *Field Studies*, **1**, 1-19.
- BÖHNING, R. H., and BURNSIDE, C. A. (1956). The effect of light intensity on rate of apparent photosynthesis in leaves of sun and shade plants. *Am. J. Bot.*, **43**, 557-567.
- CLARK, M. E. (1968). The ecology of supralittoral rockpools with special reference to the copepod fauna. *Ph.D. thesis. University of Aberdeen, Scotland.*
- DANIEL, M. J. (1971). Aspects of the physiology of the intertidal teleost *Blennius pholis* (L.). *Ph.D. thesis. University of London.*
- DAVIES, P. S. (1966). Physiological ecology of *Patella* I. The effect of body size and temperature on metabolic rate. *J. Mar. biol. Ass. U.K.*, **46**, 647-658.
- GANNING, B. (1967). Laboratory experiments in the ecological work on rockpool animals with special notes on the ostracod *Heterocypris salinus*. *Helgoländer wiss. Meeresunters*, **15**, 27-40.
- GANNING, B. (1971). Studies on chemical, physical and biological conditions in Swedish rockpool ecosystems. *Ophelia*, **2** (1), 51-105.
- GANNING, B., and WULFF, F. (1970). Measurements of community metabolism in some Baltic brackish water rockpools by means of diel oxygen curves. *Oikos*, **21**, 292-298.
- HARVEY, H. W. (1955). *The Chemistry and Fertility of Seawaters*. C.U.P. London.
- HOAR, W. S. (1966). *General and Comparative Physiology*. (1st Edition.) Prentice Hall. Englewood Cliffs.
- HOAR, W. S., and HICKMAN, C. P. (1967). *A Laboratory Companion for General and Comparative Physiology*. Prentice Hall. Englewood Cliffs.
- KLUGH, A. B. (1924). Factors controlling the biota of tide pools. *Ecology*, **5**, 192-196.
- LEWIS, J. R. (1964). *The Ecology of Rocky Shores*. E.U.P. London.

- NAYLOR, E., and SLINN, D. J. (1958). Observations on the ecology of some brackish water organisms in pools at Scarlett Point, Isle of Man. *J. Anim. Ecol.*, **27**, 15-25.
- NEWELL, R. C. (1970). *Biology of Intertidal Animals*. Logos, London.
- NEWELL, R. C., AHSANULLAH, N., and PYE, V. I. (1972). Aerial and aquatic respiration in the shore crab *Carcinus maenas* (L.). *Comp. Biochem. Physiol.*, **43A**, 239-252.
- PROSSER, C. L. (1961). *Comparative Animal Physiology*. (Prosser, C. L., and Brown, F. A., eds.) Saunders, Philadelphia.
- PYEFINCH, K. A. (1943). The intertidal ecology of Bardsey Island, North Wales, with special reference to the recolonization of rock surfaces, and the rock pool environment. *J. Anim. Ecol.*, **12**, 82-108.
- RANADE, M. R. (1957). Observations on the resistance of *Tigriopus fulvus* (Fischer) to changes in temperature and salinity. *J. Mar. biol. Ass. U.K.*, **36**, 115-119.
- RAYMONT, J. E. G. (1963). *Plankton and Productivity in the Oceans*. (1st edition.) Pergamon, London.
- SPECTOR, W. S. (Ed.) (1956). *Handbook of Biological Data*. Saunders, Philadelphia.
- STEPHENSON, T. A., ZOOND, A., and EYRE, J. (1934). The liberation and utilization of oxygen by the population of rock pools. *J. exp. Biol.*, **11**, 162-172.
- STRICKLAND, J. D. H., and PARSONS, T. R. (1968). *A Practical Handbook of Seawater Analysis*. Fish. Res. Bd. Can., Bull., 163.
- TAYLOR, E. W., and BUTLER, P. J. (1973). The behaviour and physiological responses of the shore crab *Carcinus maenas* during changes in environmental oxygen tensions. *Neth. J. Sea. Res.*, **2**, 496-505.